

Encoder A200/136

OrderNo.:41200034-01000
18.10.2019 / 0

Technical data

Pulse-rate	1000
Channels	A,A/,B,B/,N,N/
Signals	square wave
Supply voltage	5V
Output voltage	5V
Output frequency	300kHz
Cable/Connector entry	radial
Pin assignment	ST3450A
Shaft design	10Glatt/19,5
Enclosure rating	IP67
Limit temperature	0/+80°C
Shaft load axial	10N
Shaft load radial	20N
Current (unloaded)	max. 120mA
Weight	0,3kg
DRAWING NO.	41-200-034-

GL	Wellenausführung glatt / shaft type cylindrical
FL	Wellenausführung mit Fläche / shaft type with flat surface
N	Wellenausführung mit Nut / shaft type with slot
Hohlw	Hohlwelle / hollow shaft
Klemme	mit Klemmring / with clamping ring
Grundw	Grundwelle / fundamental shaft
SLG	Seillängengeber / cable retractor
ZB	Zentrierbund / centre ring
Tachofl	Tachoflansch / tachometer flange
DAG	DAG-Schutzgehäuse / DAG protective housing
TK	Teilkreis / pitch circle

Subject to change.

Mechanische Abmessungen für Gebertyp AMI
Mechanical dimensions encoder-type AMI
A200/136 (41200034-XXXXX)

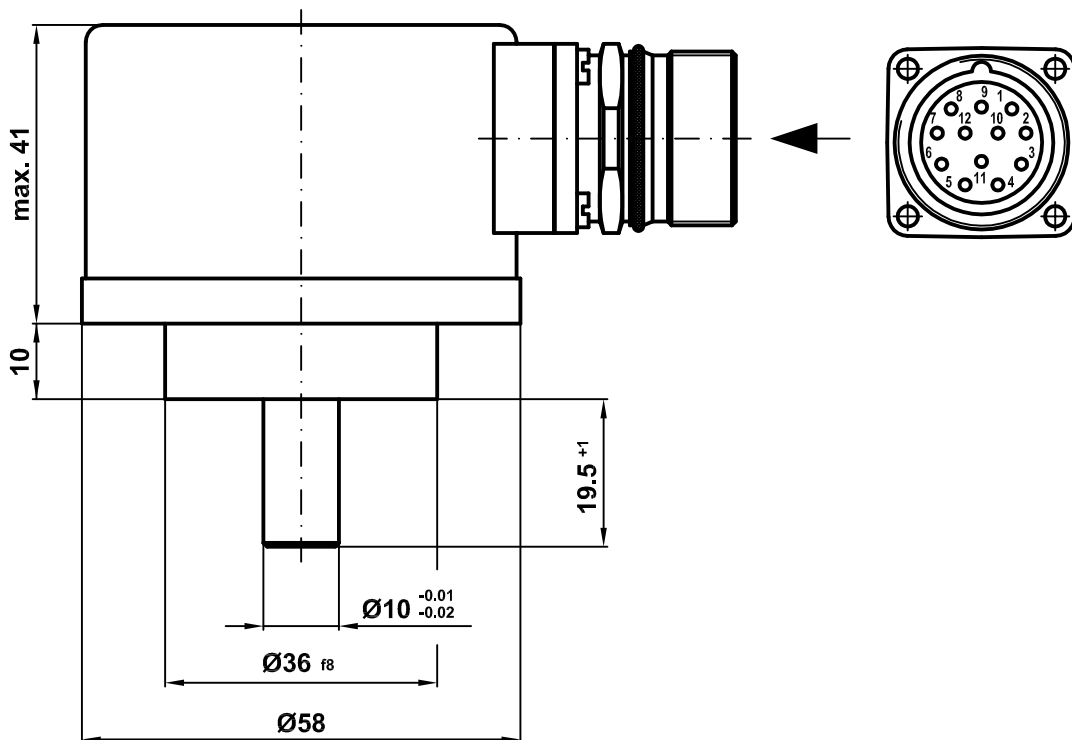
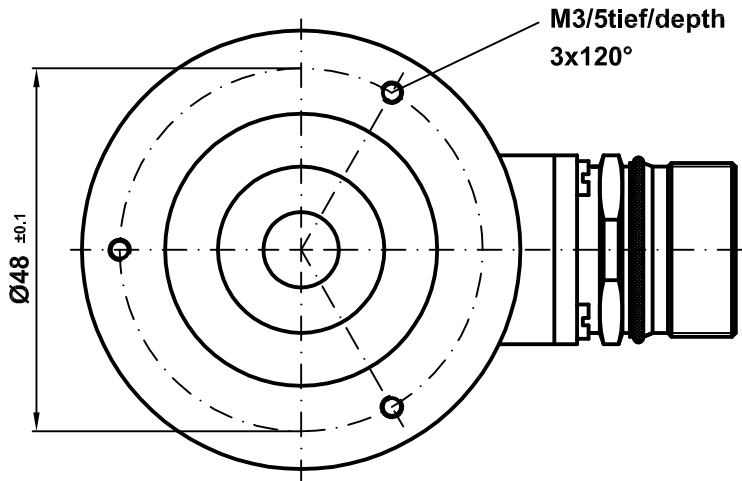

Pin assignment

Pin assignment number: 3450

Index: A

10.05.2017

Connector name: 12-pol CONTACT

Pin-count: 12

Page: 1/1

Pin	Designation	Description	Level	Driver	NC	Colour
1	/CH_B_OUT	Channel B inverted	5V	RS 422		brown
2	Ub sensor	Supply voltage	5V			green
3	CH_I_OUT	Channel Reference	5V	RS 422		yellow
4	/CH_I_OUT	Channel Reference inverted	5V	RS 422		gray
5	CH_A_OUT	Channel A	5V	RS 422		pink
6	/CH_A_OUT	Channel A inverted	5V	RS 422		orange
7	not connected					
8	CH_B_OUT	Channel B	5V	RS 422		black
9	Screen	Shield				brown/white
10	Ground IN	Ground	0V			violet
11	0V sensor	Ground	0V			blue
12	Supply Voltage IN	Supply voltage	5V			white

WARNING

'De-energize the system before carrying out wiring work or opening and closing electrical connections !

Short-circuits, voltage peaks, etc. can cause operating failures and uncontrolled operating states, as well as serious personal injuries and damage to property.

Verdrahtungsarbeiten, Öffnen und Schließen von elektrischen Verbindungen nur im spannungslosen Zustand durchführen ! Kurzschlüsse, Spannungsspitzen etc. können zur Fehlfunktion und unkontrollierten Zuständen der Anlage bzw. zu erheblichen Personen- und Sachschäden führen.